



**MACCHINE STANDARD E SPECIALI
IMPIANTI COMPLETI DI FINE LINEA
PER L'IMBALLAGGIO PRIMARIO
E SECONDARIO DEI PRODOTTI
FOOD E NON FOOD**



**СТАНДАРНОЕ И СПЕЦИАЛЬНОЕ
ОБОРУДОВАНИЕ
КОМПЛЕКСНЫЕ УСТАНОВКИ ДЛЯ
ЗАВЕРШАЮЩЕГО ЦИКЛА
ПЕРВИЧНОЙ И ВТОРИЧНОЙ
ПИЩЕВЫХ И НЕПИЩЕВЫХ
ПРОДУКТОВ**



**ITAL
TECHNOLOGY**



ITAL 250 60+60 / minute
Erecting machine - Double Head

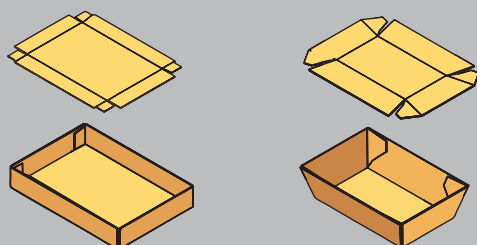

ITAL 285 60 / minute
Erecting machine - Single Head

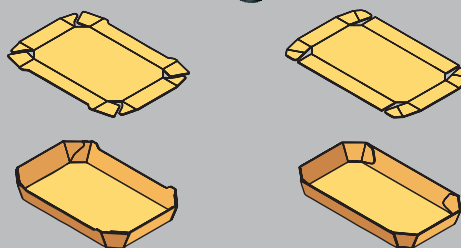

ITAL 600 45 / minute
Automatic erecting machine

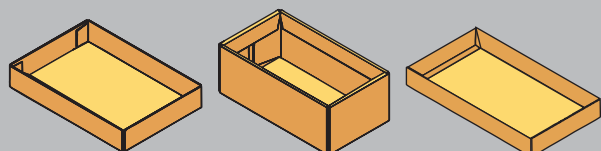

ITAL 555 40 / minute
Automatic erecting machine

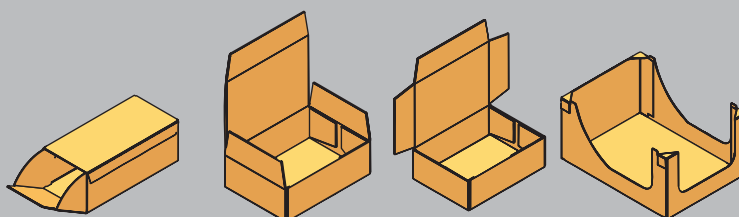

ITAL 595 25 / minute

Trays erecting machine - Single face carton
Cold glue

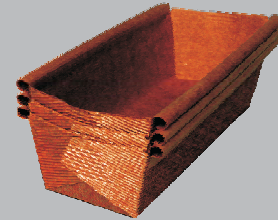
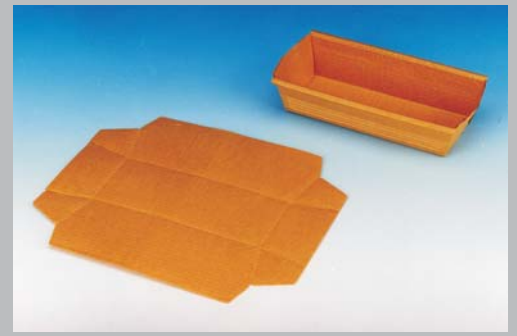
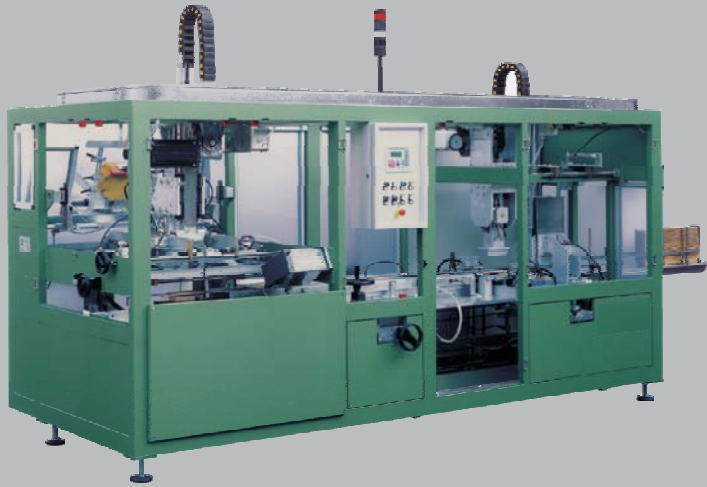

ITAL 724 20÷22 / minute

Trays erecting machine - Compact carton
Cold Glue

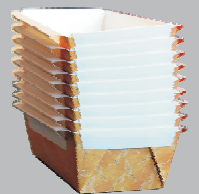
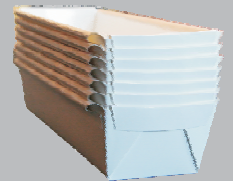

ITAL 809 max 45 reams / minute

Integrated line for boxes (bottom and lid)
with paper reams (A3-A4)



ITAL 245 100 / minute
Folding sheath, filling and closing machine - Horizontal



ITAL 640 120 / minute
Folding sheath, filling and closing machine - Horizontal

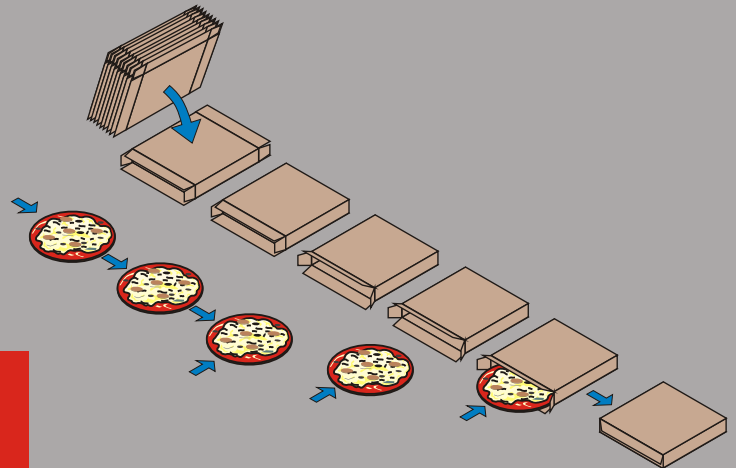
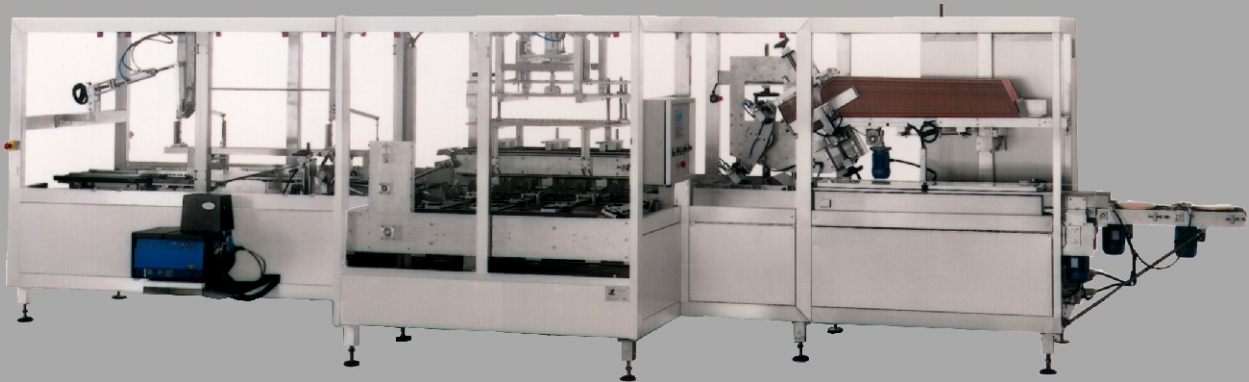

ITAL 744 40÷45 / minute
Intermittent cartoning machine



ITAL 813 50÷100 / minute
Sleeve Machine



ITAL 840 80÷100 / minute
Packaging machine for cluster



ITAL-113 N 60 / minute
Erecting machine - using joint hooks

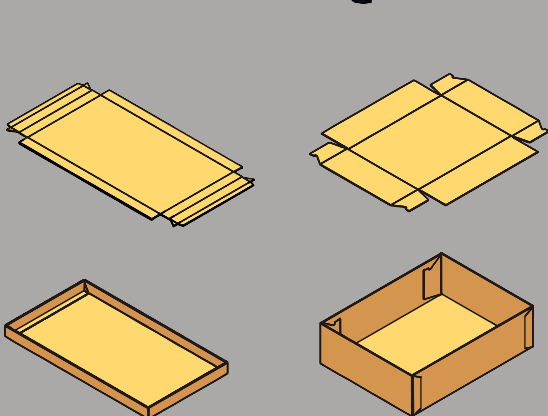

ITAL3-651 80 / minute
Closing machine - 3 flaps boxes

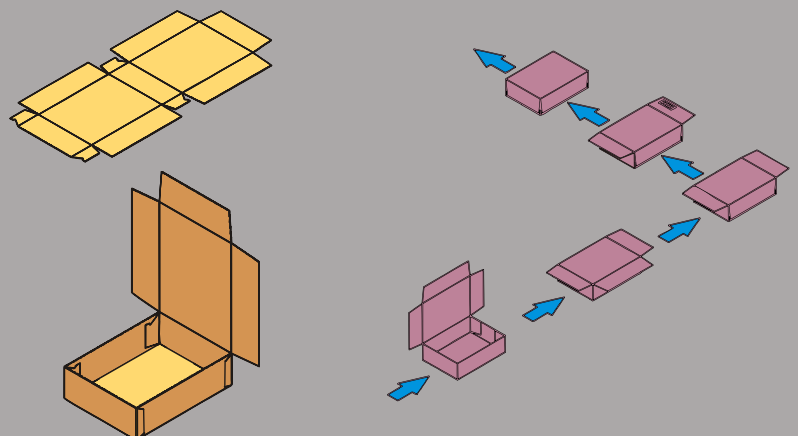

ITALR 650

70÷90 / minute

Erecting machine of conic and clamshell boxes - cold glue



ITAL 670

40÷45 / minute

Automatic erecting machine without glue

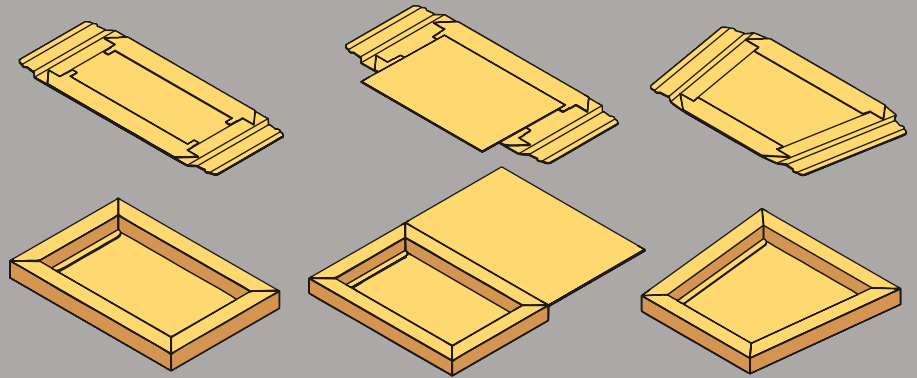

SHOE-BOXES LINE

45 / minute

Automatic line to form and cover shoe boxes

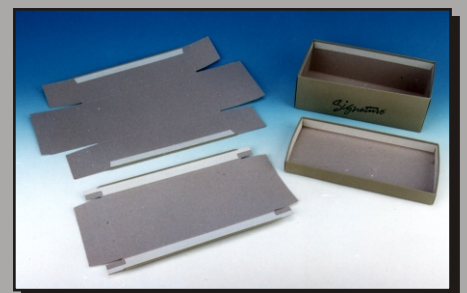
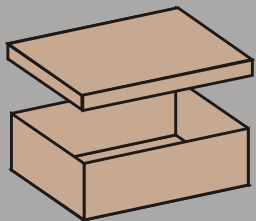

ITAL 116 18 / minute
Box closing machine



ITAL LINE 540/560 25 / minute
Automatic line to form, fill, close and label boxes containing: screws, bolts and nails.

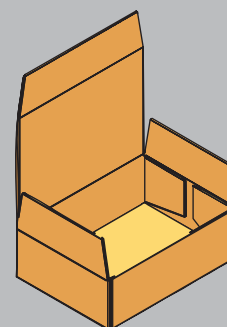
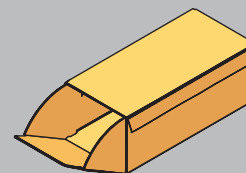

ITAL 590 12 / minute
Automatic carton erector

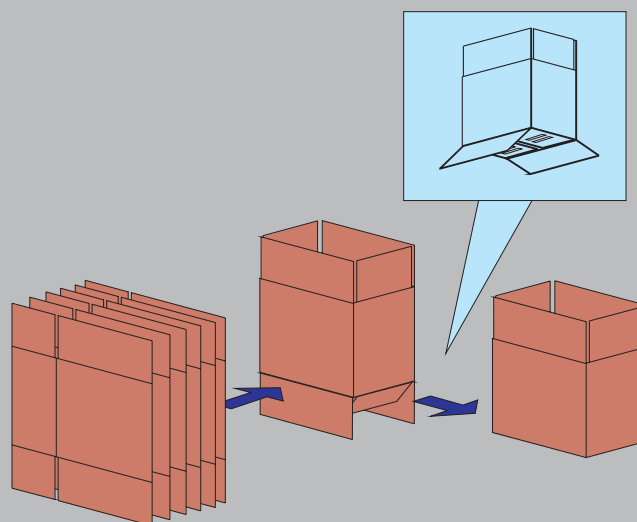
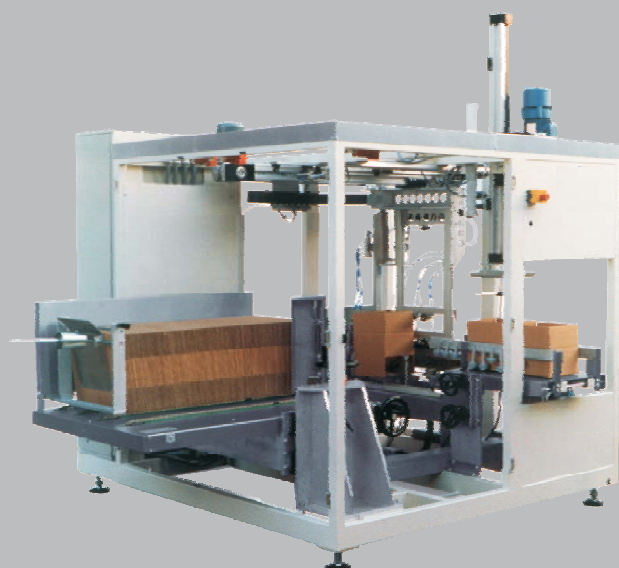

SPECIAL PACKAGING MACHINES, INTEGRATED UNITS, ROBOTING PACKAGING WORKCELL



Progetta e realizza: macchine standard e speciali, impianti completi di fine linea per l'imballaggio primario e secondario dei prodotti food e non food

La gamma comprende: Sistemi di trasporto, selezione, smistamento, accumulo e raggruppamento prodotti; Macchine formatrici a media ed alta velocità per scatole piccole, medie, grandi, vassoi, ecc.; Macchine per scatolifici e cartotecniche; Linee complete di imballaggio con formazione, riempimento del prodotto e chiusura della scatola; Astucciatrici orizzontali a funzionamento intermittente o continuo; Fascettatrici per prodotti tondi, ovali, rettangolari a media e alta velocità.

Tutte le macchine ITAL TECHNOLOGY sono certificate CE.

We design and produce standard and special packaging machines and solutions, our equipment includes a complete range for end of line primary and secondary packaging for food and non food products.

Within our range are: Systems for the transport,

products; Erecting machines, both moderate and high speed for trays and boxes ranging from the very smallest to large sizes; Complete turn key lines for packing that comprise erecting, product filling and closing of the box; Horizontal cartoning machines with intermittent or continuous operation; Sleeve machines for round, oval and rectangular products with medium and high speed; Equipment to 'product wrap' in board materials and to seal thin profile packages/wallets; Machines designed to be used in-house by carton and packaging factories and within the paper industries.

All machines manufactured by ITAL TECHNOLOGY are CE certified

Проектирует и реализует:

Стандартное и специальное оборудование, комплексные установки для завершающего цикла первичной и вторичной упаковки пищевых и непищевых продуктов.

Гамма продукции включает:

Системы транспортировки, отбора, сортировки, накопления и группировки продукции;

Средне- и высокоскоростные формователи коробок малых, средних и больших размеров, поддонов и т.д.

Оборудование для производств по выпуску тары и упаковок;

Комплексные упаковочные линии, выполняющие формирование, заполнение продукцией и запечатывание коробок;

Горизонтальные машины по производству футляров, как непрерывного, так и прерывистого цикла;

Средне- и высокоскоростные обандероливающие машины для продукции круглой, овальной и прямоугольной формы

Conception et réalisation de machines standards et spéciales, installations complètes de fin de ligne pour l'emballage primaire et secondaire de produits alimentaires et autres

La gamme comprend: Systèmes de convoyage, sélection, tri, accumulation et regroupage de produits; Formeuses de boîtes, de barquettes de petites, moyennes et grandes dimensions à des cadences moyennes et élevées; Formeuses de boîtes pour l'industrie du papier et de la cartonnerie; Lignes complètes d'emballage avec formation, chargement du produit et fermeture de la boîte; Etuyeurs horizontaux à fonctionnement intermittent ou continu; Machines de dépôt d'un bandeau-carton pour produits ronds, ovales ou rectangulaires travaillant à des vitesses moyennes ou à hautes cadences

Les machines ITAL TECHNOLOGY sont fabriquées conformément aux normes CE.

Proyectamos y realizamos: Máquinas especiales y estándares, plantas completas de final de línea para el embalaje primario y secundario de alimentos y no de productos no alimenticios.

La gama incluye: Sistemas del transporte, selección, acumulación y agrupación; Máquinas formadoras de cajas de media y alta velocidad para cajas pequeñas, medias, grandes, bandejas, etc.; Máquinas para las fábricas de cajas y para la industria del papel; Líneas completas de embalaje con formación, llenado con producto y cierre de la caja; Estuchadoras horizontales de funcionamiento intermitente y continuo; Envolvadora para productos redondos, ovalados, rectangulares a media y alta velocidad.

Todas las máquinas ITAL TECHNOLOGY están certificadas por la CE

ITALIA: 20066 MELZO (MI)

Via 1° Maggio 15

Tel. +39 02 95710580

Fax +39 02 95738971

РОССИЯ: 111123 МОСКВА

шоссе Энтузиастов

Д.56, строение 44, этаж 10

Тел./факс +7(495)306-6734, (495)368-6431, (495)748-5182

E-mail: ritec@co.ru - www.italtechnology.ru

РОССИЯ: 191040 С-ПЕТЕРБУРГ

Лиговский пр. Д.56-Б офис 404

Тел. (812) 713-3715

Факс (812) 764-5609

E-mail: italtech@inbox.ru